

**Input**

Rated input voltage	100 V ~ 240 V ac
Input voltage range	90 V ~ 264 V ac
Rated frequency	50~60 Hz
Frequency range	47~63 Hz
Rated input current	400 mA RMS max.
Inrush current	30 A max. at 115 / 50 A max. at 230 V ac cool start
Power dissipation	< 0.3 W (CEC Compliant)

Output

Output voltage	15 V dc at 1.0 A
Output min. current	0 A
Line regulation	± 1%
Load regulation	± 5%
Over voltage protection	17.1 ~ 18.9 V dc max. (output shut down)
Short circuit protection	output shut down and auto restart
Ripple voltage	150 mV (p-p) (100~240 V ac at full load)
Efficiency	Energy Star compliant - level IV

Safety and EMI

HI-POT	input to output	3000 V ac at 10 mA for 1 minute
Insulation resistance	input to output	> 100 M Ohm at 500 V dc
Safety approvals	UL/cUL	
EMI standard	FCC class B, CE, VCCI-II	
RoHS compliant	yes	
Leakage current	0.25 mA	

Environmental

Storage temperature	-10°C ~ +70° C
Operating temperature	0°C ~ +40° C
Storage humidity	10~90%
Operating humidity	20~80%



Label

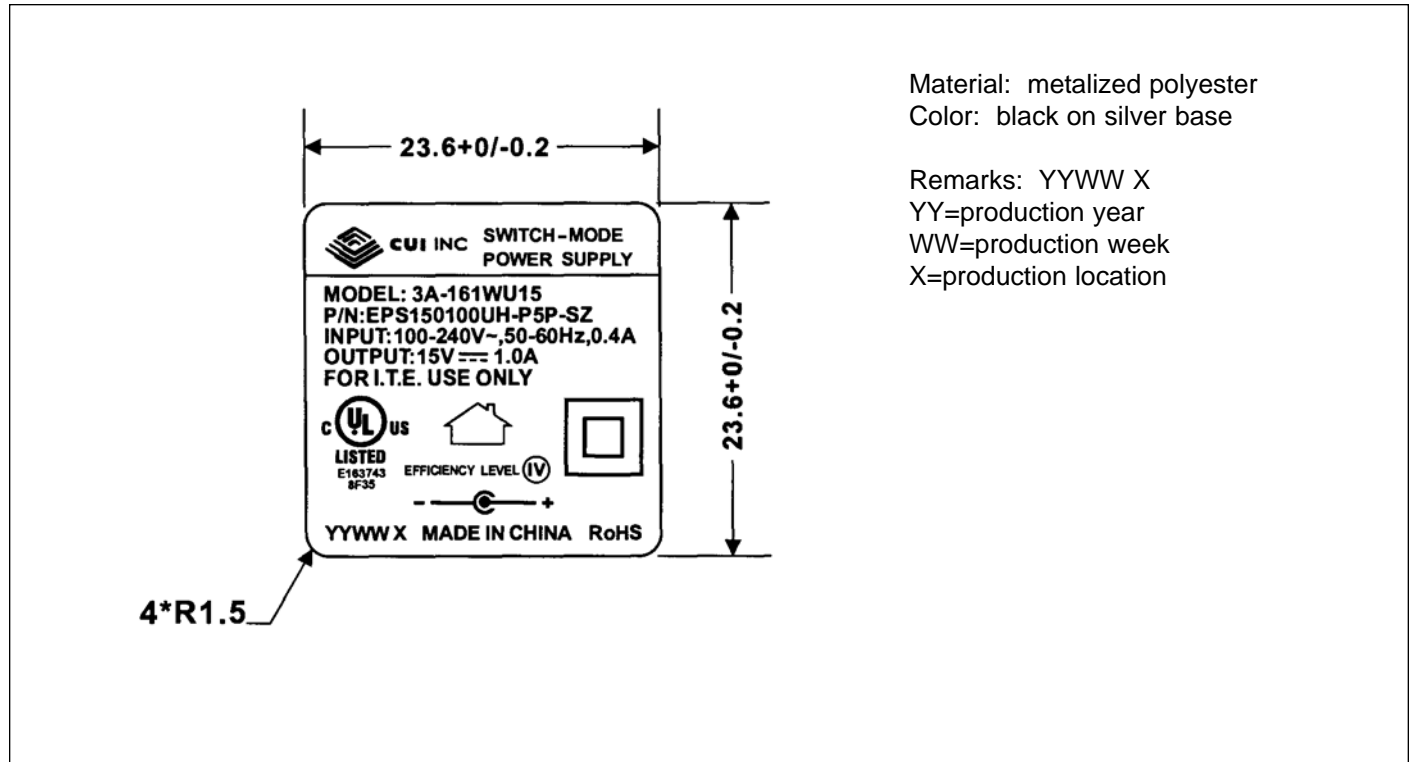



CUI INC

Part No: EPS150100UH-P5P-SZ

Description: switching power supply

Date: 6/12/2006

Unit: mm

Page No: 3 of 6

Mechanical Drawing

Tolerance: ± 1

Weight	175 g
Case size	72 L x 47.6 W x 26.5 H mm

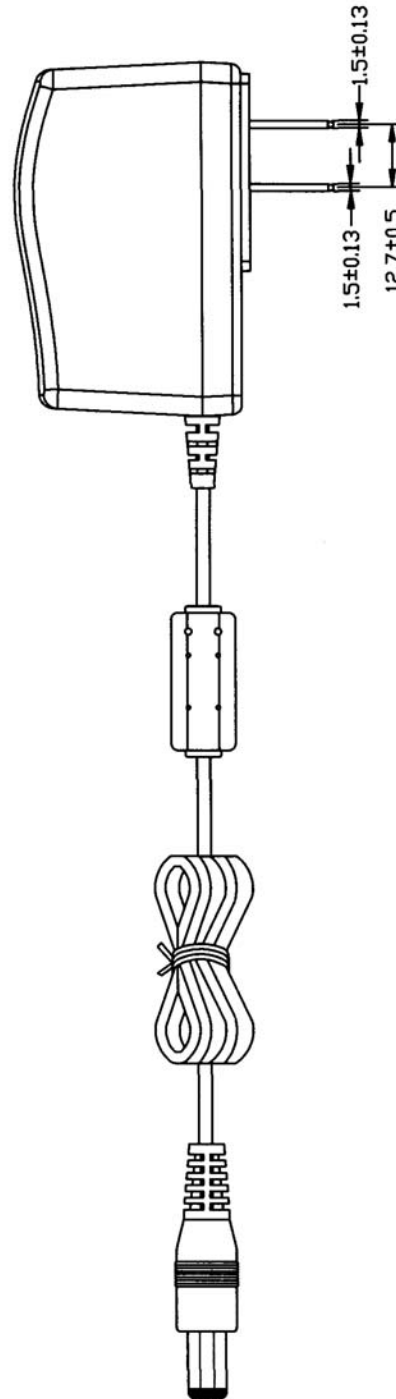
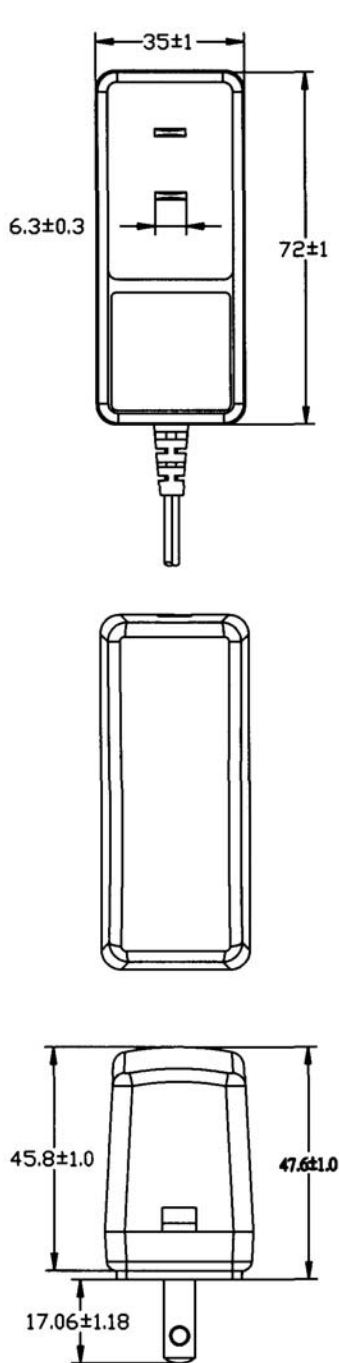



DC Cord

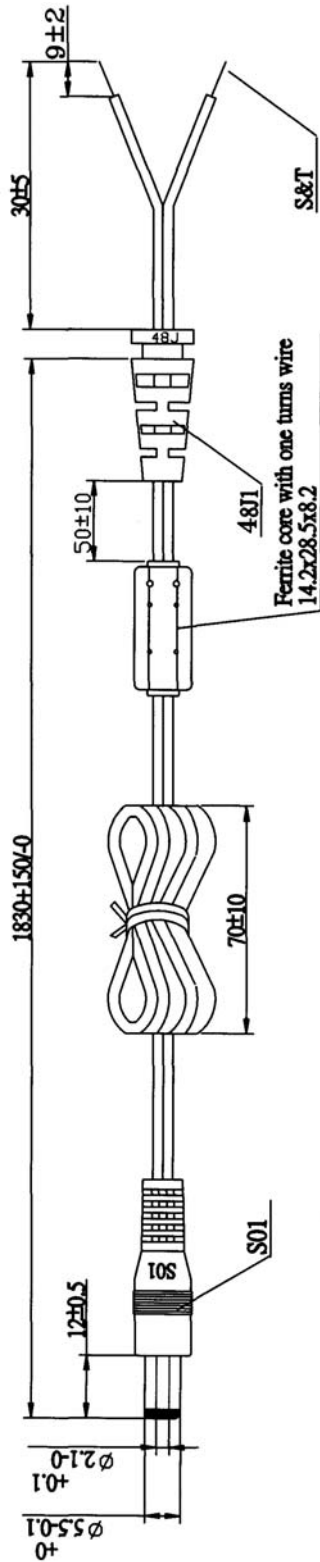

HAVE ON WORD WIRE IN OUTER, NO WORD WIRE IN INNER

#20AWGX2C UL2468

OD: Ø1.9X3.8



VIBRATION TEST	a. ±60°
	b. WEIGHT 200g
	c. 40 ROUNDMINUTE
	d. OVER 1000 COUNT MIN



CUI INC

Part No: EPS150100UH-P5P-SZ

Date: 6/12/2006

Unit: mm

Description: switching power supply

Page No: 5 of 6

Individual Packaging

Tolerance: ± 1

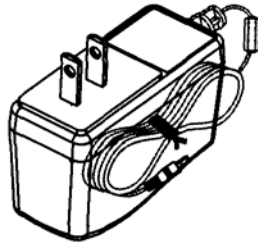

PRODUCT

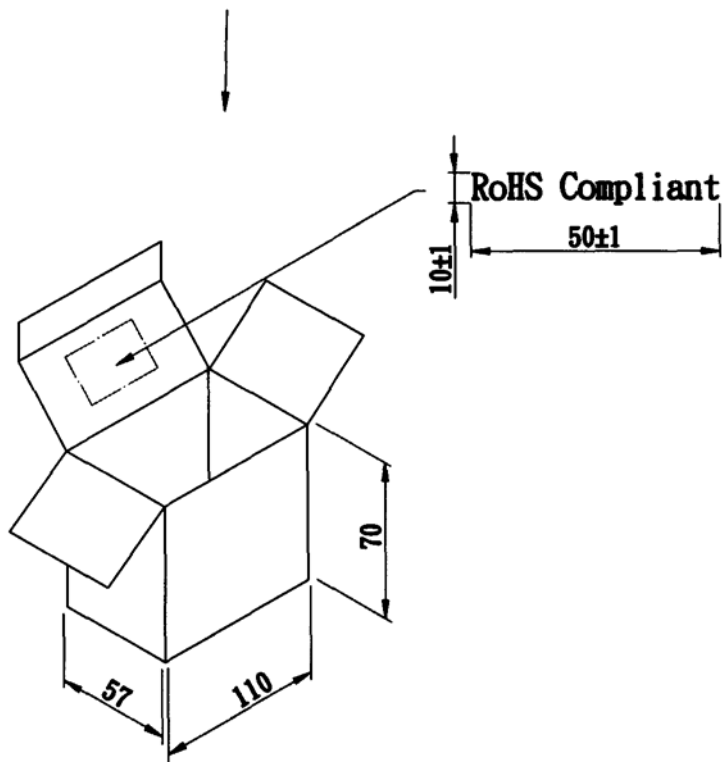



Packaging

Tolerance: +7/-0

CARTON INTERNAL SIZE:450*308*300mm

Q'TY: 80PCS(20*4)

N.W: 10.5KGS

G.W: 11.0KGS

G.W: 11.8KGS

"RoHS Compliant"

